

SPECIFICATION	VALUE
NO. of PHASES	3
NO. of POLES	4
RATED VOLTAGE(V)	24
RATED CURRENT(A)	0.72±10%
RATED POWER(W)	8.5
RATED SPEED(RPM)	10000±10%
RATED TORQUE(mN.m)	8
NO LOAD CURRENT(A)	0.25
NO LOAD SPEED(RPM)	14000
SENSOR	HALL SENSOR
INSULATION CLASS	CLASS B
INSULATION RESISTANCE	100MΩ MIN @ 500VDC
DIELECTRIC STRENGTH TEST	500VAC for 1 MINUTE
BEARING TYPE	NMB BALL BERRING, C3

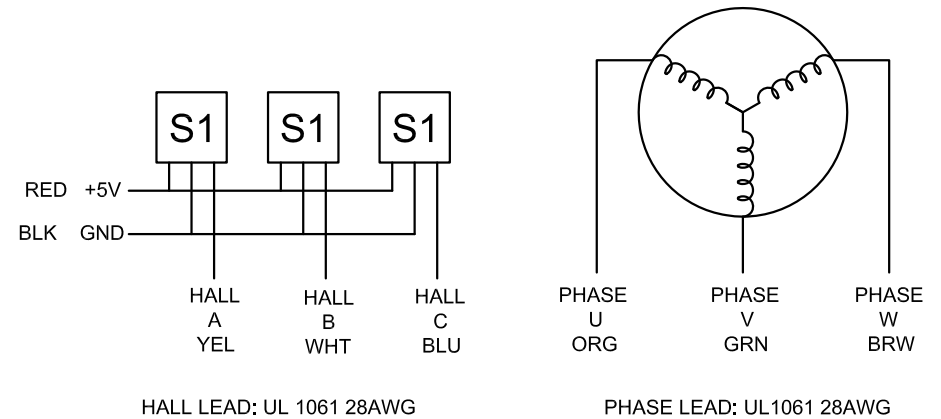

	APVD		
	CHKD		
2:1	DRN		
SCALE	SIGNATURE	DATE	

BRUSHLESS DC MOTOR

22BLR40-24-01